

# AV551805

Caleffi 551 Series DiscalSlim Air Eliminator 20mm



## Technical Specification

Materials:

Body: PPAG40

Float: PP

Float guide and stem: brass EN 12164 CW614N

Float lever and spring: stainless steel

Hydraulic seals: EPDM

Performance:

Medium: water, non-hazardous glycol solutions

Max. percentage of glycol: 30%

Max. working pressure: 3bar

Max. discharge pressure: 3bar

Working temperature range: 0–110°C

Connections:

3/4" F (ISO 228-1)

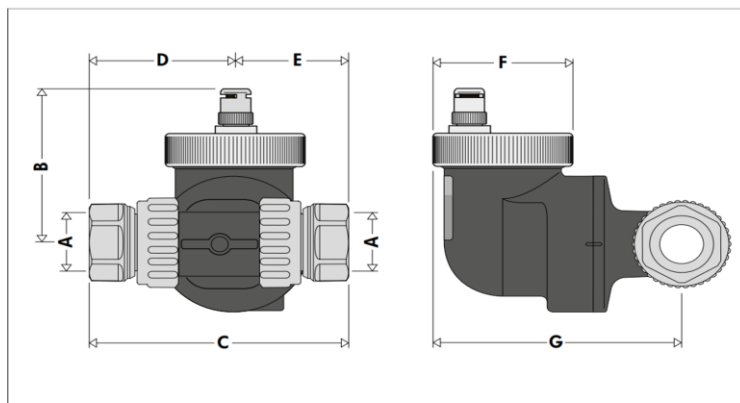

Code	A	B	C	D	E	F	G	Weight kg
551805	3/4"	71	105	58,5	46,5	56	101	0,634
551806	1"	71	118	65	53	56	101	0,766

## Application

The Caleffi 551 Series DiscalSlim Air Eliminator 20mm is used in heating & cooling systems to eliminate circulating air and is installed mostly in plant rooms.

## Warranty

[Download the latest warranty statement](#)

## Features

The DiscalSlim devices can autonomously and continuously discharge the air from climate control circuits, down to the micro-bubble level (slow, continuous degassing).

Circulation of fully deaerated water allows the systems to operate in optimal conditions, free from any noise, corrosion, localised overheating or mechanical damage.