

HPG16

Grant Aerona Heat Pump 16kW



Technical Specification

- Heat output: 16kW (Water 35°C / Air 7°C D.B)
- COP: 4.19 (30/35°C / 7°C D.B)
- Power supply: 230V/1Ph/50Hz
- Max heating temp: 55°C
- Sound power level (40/45°C / 7°C D.B): 63dBa
- Dry weight: 121kg

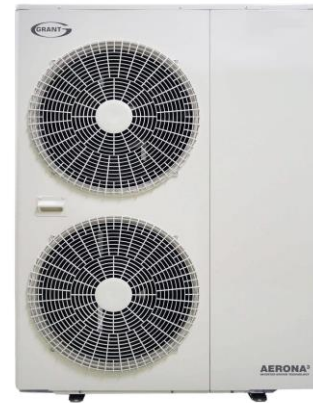

HPID16

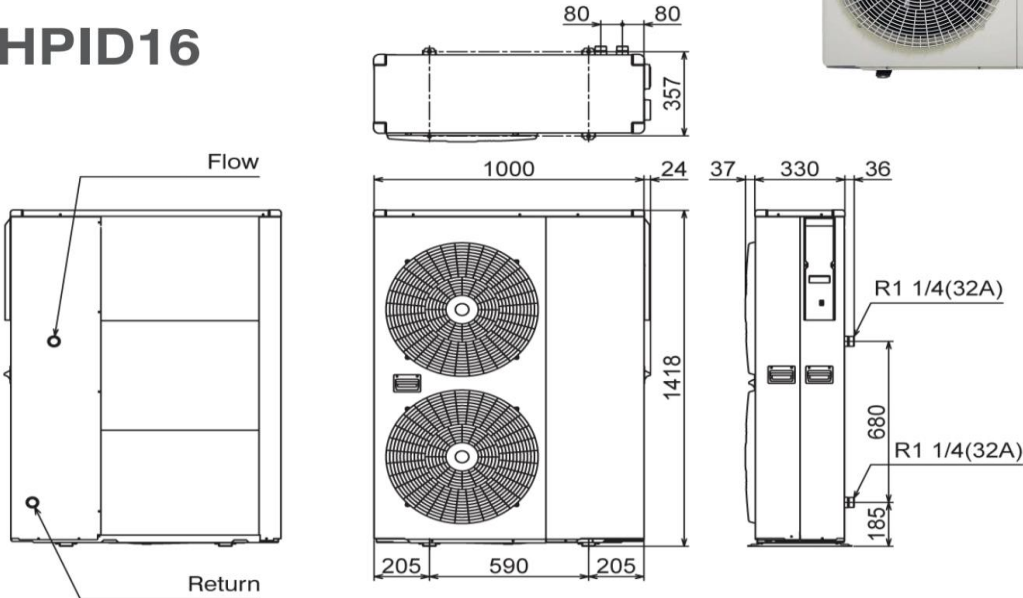

Application

The Grant Aerona Heat Pump 16kW is used in heating systems to generate hot and cold water using electricity and is installed mostly outside the plant room.

Warranty

[Download the latest warranty statement](#)

Features

- High efficiency air to water heat pump for underfloor heating
- Able to heat medium to large homes via under floor systems even under extreme conditions helped by a variable speed fan and water pump technology
- Extremely quiet operation with soft start technology
- Floor standing, outdoor
- 1418mm high x 1000mm wide x 356mm deep
- Made in Ireland